

Eagle E265 Platform



The Eagle E265 is an automated trolley that can be used for part delivery or can be equipped with a trailer hitch for use as a low cost trolley. The Eagle E265 is capable of carrying loads up to 250 lbs. with a towing capacity of 500 lbs. These mobile robots can replace conveyors or manual pickup/delivery systems with a flexible automated system that links all production areas in a factory or warehouse.

An electro-mechanical drive unit allows for a great deal of flexibility in movement and speed. The single wheel suspension keeps the drive wheel in contact with the floor at all times. All wheels feature extra thick polyurethane tread for long life and noiseless operation. Electro-mechanical brakes are included as an integral part of the permanent magnet motor and sealed gearbox assembly. Each Eagle E265 is equipped with a 12-volt battery power source. Vehicle mounted slow-down sensors monitor obstructions while the vehicle is in motion.

Features

- ▶ Removable covers Provides Ease of Access to the Drive Assembly and All Electrical Components.
- ▶ Optional attachments such as Tote Shuttles, Trailer Hitches and Auto-charging are Available for the Eagle E265.
- ▶ Corecon's Modular Control System separates AGV Functions making problem Diagnosis Quicker Reducing AGV Downtime.
- ▶ AGV Safety Devices Meet and Exceed ANSI and OSHA Standards for AGVs.

Benefits

- ▶ Low Cost of Ownership
- ▶ Ease of Maintenance
- ▶ Easy Access to All Major AGV Components
- ▶ Modular Design for Faster Diagnosis & Quick Repair
- ▶ Simple AGV Deployment
- ▶ Variety of Tooling Available for Many Eagle AGV Applications

AGV Options

- ▶ Laser Sensor for Obstacle Detection
- ▶ Optical Communication
- ▶ Radio Communication
- ▶ Sealed Batteries
- ▶ Opportunity Charging
- ▶ Quick Charge Batteries

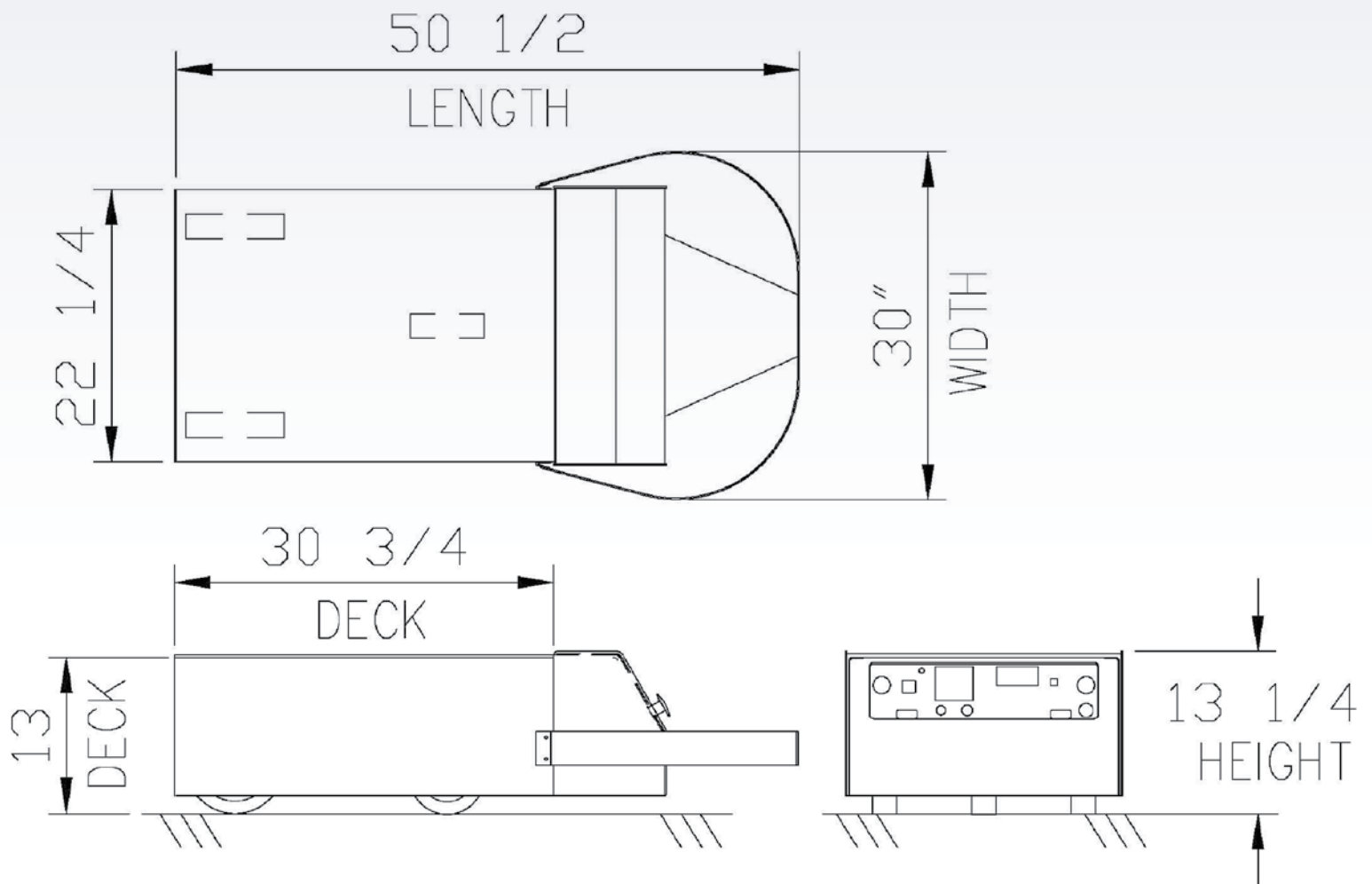

Performance

Speed Forward:	120 ft./Min.Max
Stopping and Repetitive Stopping Accuracy:	+/- 1/2"
Minimum Cornering Radius:	24"
Load Capacities:	250 Lbs.
Towing Capacity:	500 Lbs.
Battery Capacity (Standard):	150 Amp/Hr

Size / Weight

Overall Length:	50.5"
Overall Width:	30"
Overall Height:	13.2"

